

SOMETHING LIKE THESE DRAWINGS
ARE MY EXPECTATIONS FOR
TOMORROW 9/21/2022

- *You can use your computer, but you know that I prefer your sketches by hand.*
- *Use your iPad if you have one.*
- *Print your plans 1/8*
- *Bring all the necessary tools to work in studio*
- *Keep in mind that having more knowledge and information about your project will be beneficial for you.*
- *It will be simpler for me to assist you and get to work on the design part right away.*

PRODUCT LINE & SERVICES

FIRST FLOOR

- Market
- Garden/Lounge
- Pop-up's
- Stage
- Dining

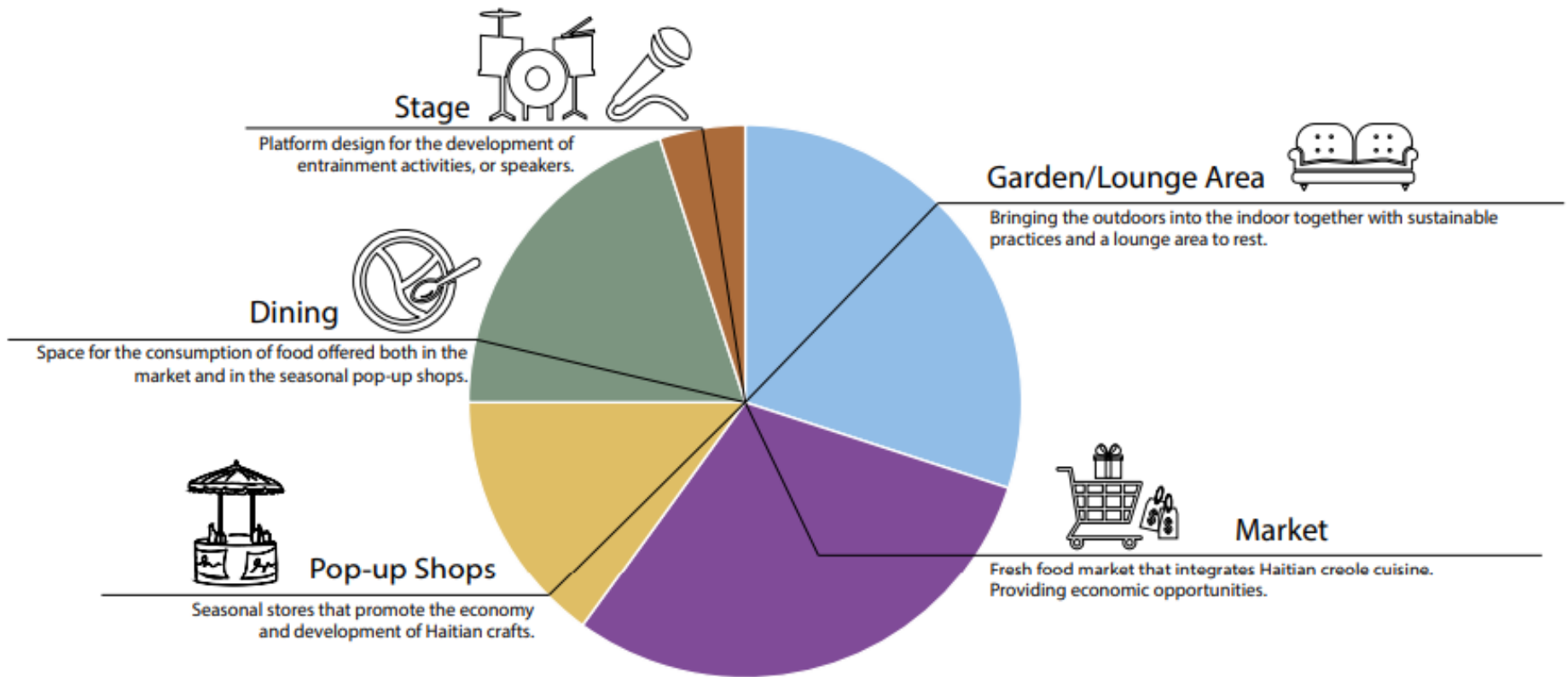

PRODUCT LINE & SERVICES

SECOND FLOOR

- Library
- Lobby/Lounge
- Classrooms
- Meeting/Network

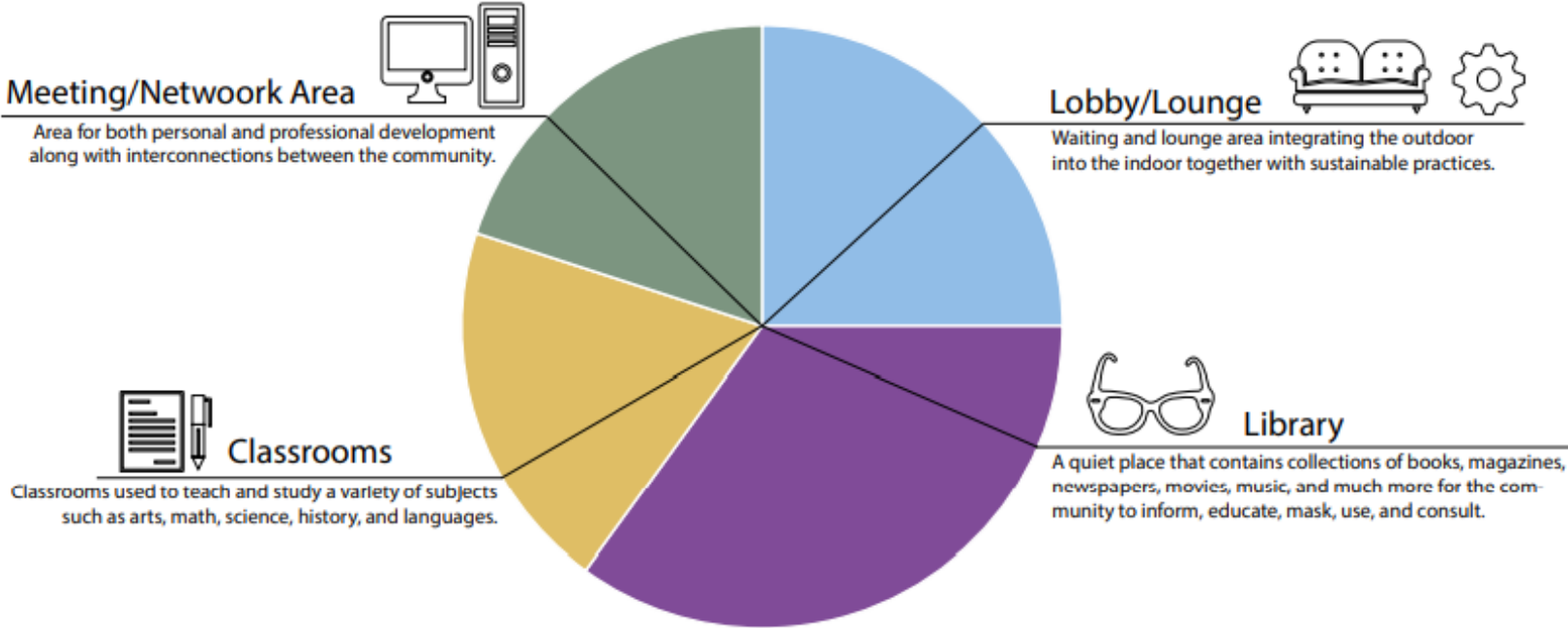

FIRST FLOOR

AREA	SPACE	FUNCTION	SQFT	PROX.
PUBLIC	Entrance Hall	Welcoming area to the public located in the south main access of the building.	980 sq ft	Elevators Stairs Garden
	Garden Lounge Area	Integrating the outdoor into the indoor together with sustainable practices such as recycling, and lounge areas to rest and hangout.	1,550 sq ft	Stage Dining Market Pop-up Shops Stafe Area
	Market	Bringing the traditional Haitian Cousin into the community to develop new economic opportunities.	460 sq ft	Entrance Hall Garden Dining Restrooms
	Dining	Area to rest and enjoy food from the market and pop- up shops.	1,320 sq ft	Garden Stage Market Pop-up Shops Restrooms
	Pop-up Shops	Heritage and traditional hand crafts seasonal pop-up shops such as pottery, jewelry, cloth, accessories, snacks, and more.	195 sq ft	Garden Dining
	Stage	Plataforma in the center of the garden mainly to entreating people that are dining.	100 sq ft	Garden Dining
SEMI PUBLIC	AID Room	Room that provides help, health, assistance, and support specially in cases of accidents.	145 sq ft	Garden Restrooms
	Restrooms	A semi-private space to take a private or personal break.	510 sq ft	Garden AID Room Management Office Maintanance Room
PRIVATE	Managment Offic	Office designed for the management and administration of the functions and activities of the building.	245 sq ft	Garden Restrooms Maintanance Room
	Maintenance Room	Office designed for the care and maintenance of the building.	130 sq ft	Garden Management Office

SECOND FLOOR

AREA	SPACE	FUNCTION	SQFT	PROX.
PUBLIC	Garden Lobby Lounge Area	Welcoming to the Educational Center and Lounge Area.	1,045 sq ft	Library Meeting/Network Classrooms Stairs/Elevators
SEMI PUBLIC	Library	Space that contains collections of books, periodicals, films, and music for people to read, borrow, or refer to.	1,500 sq ft	Lobby Meeting/Network Restrooms
	Meeting Network Area	An area to develop communications with the community.	375 sq ft	Lobby Library Classrooms Restrooms
	Classrooms	Space to expand knowledge through the teaching of professionals.	705 sq ft	Lobby Meeting/Network Restrooms
	Restrooms	A semi-private space to take a private or personal break.	510 sq ft	Classrooms Directors Office
PRIVATE	Directors Office	Private space for a particular person in charge of an activity, department, or organization.	245sq ft	Restrooms Classrooms Lobby
	Service Room	Private space for the staff that works in the educational center, to rest and organize.	130 sq ft	Lobby Directors Office

BUBBLE DIAGRAM

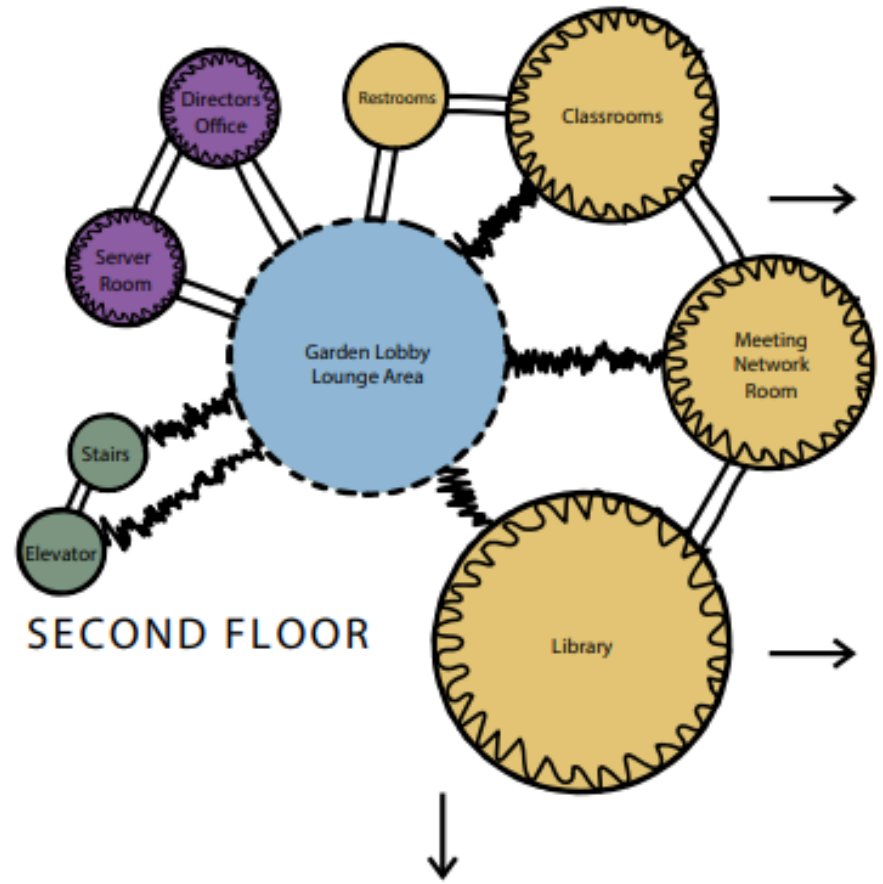
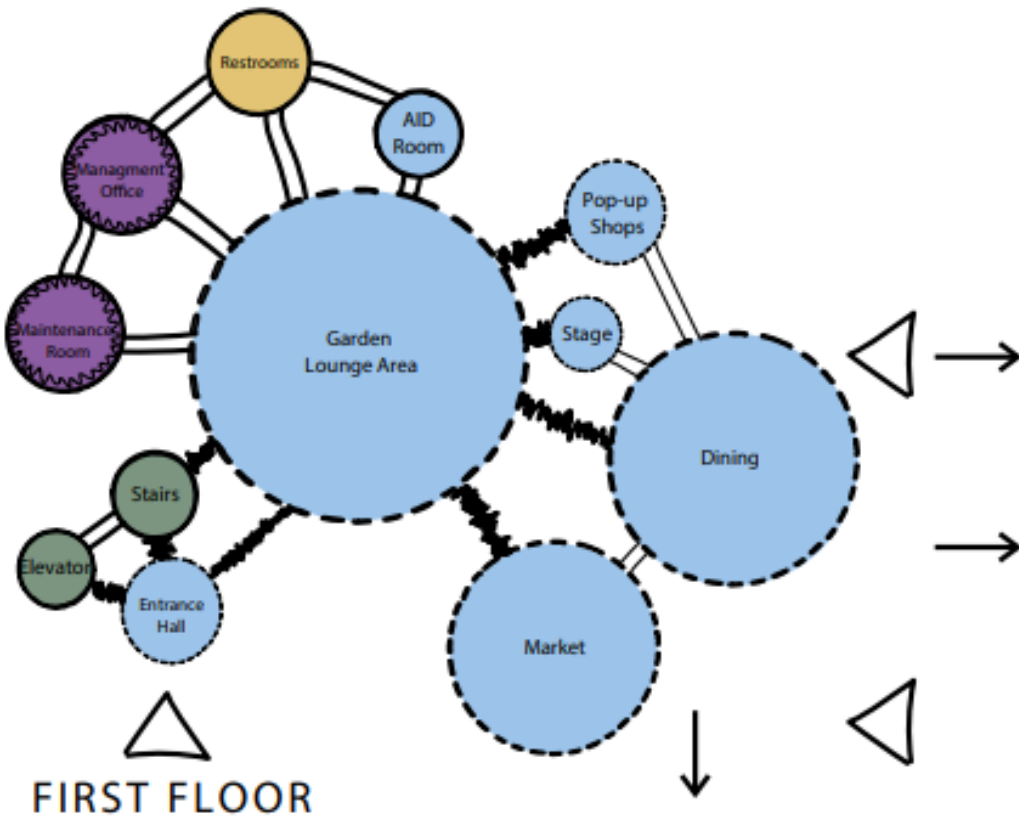
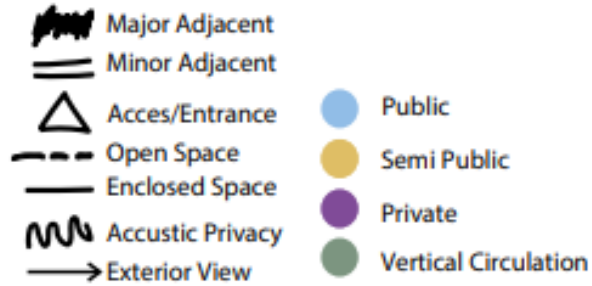

BLOCK DIAGRAM

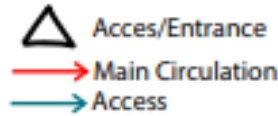

- Public
- Semi Public
- Private
- Vertical Circulation

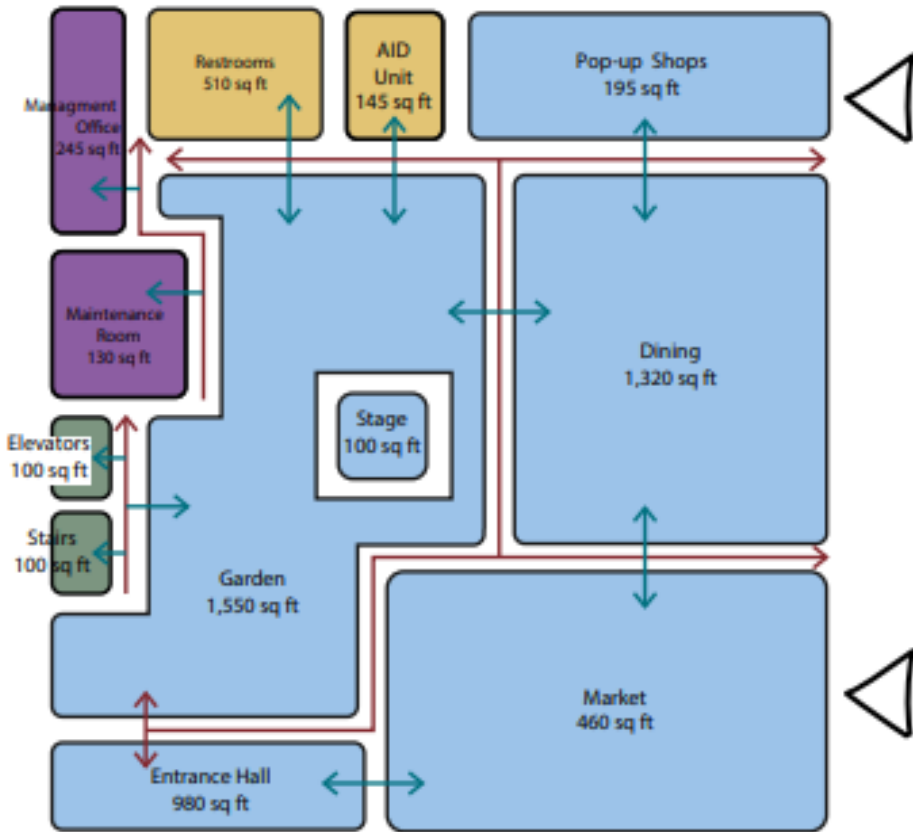

FIRST FLOOR

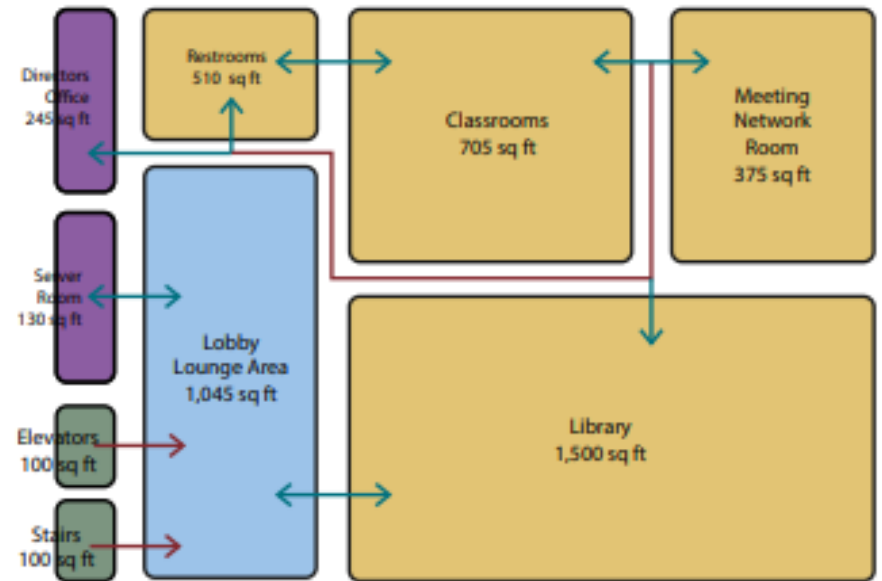

SECOND FLOOR

PARTI DIAGRAM

→ Primary Path
→ Secondary Path

- Domain
- Center
- Arrival
- Nodes

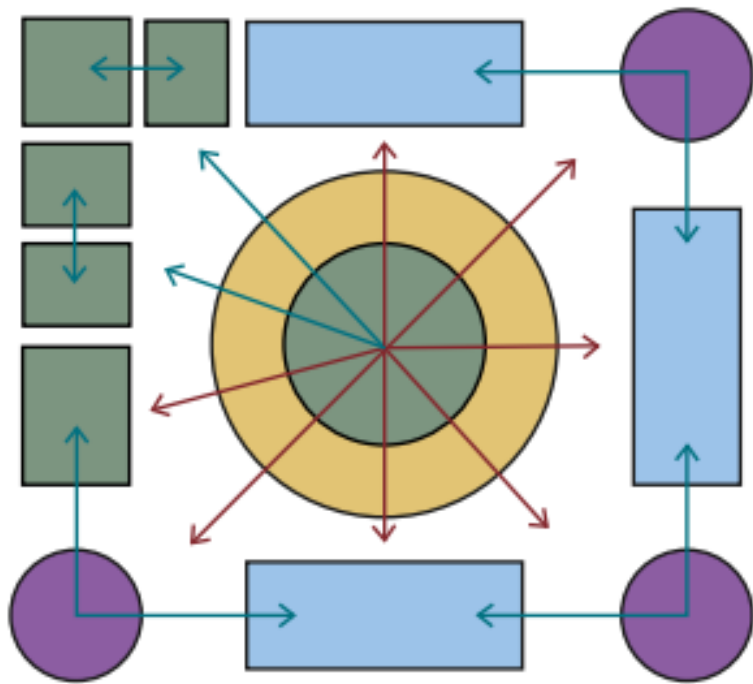

FIRST FLOOR

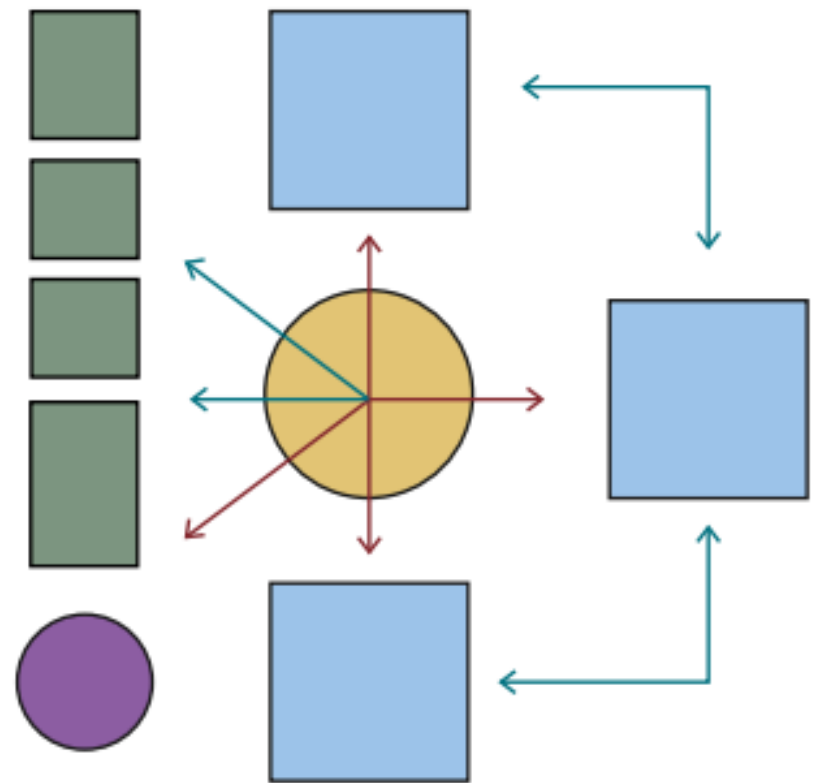

SECOND FLOOR